

- General Notes
- DRIVEWAY BUILDUP:
 - 12" - TYPE A GRAVEL
 - 2" - 12.5mm BASE COURSE
 - 1" - 9.5mm SURFACE
 - ROADWAY BUILDUP
 - 15" - TYPE D GRAVEL
 - 3" - TYPE A GRAVEL
 - 2" - 12.5mm HMA BASE
 - 1.5" - 12.5mm HMA SURFACE
 - ROADWAY WIDTHS
 - STA. 1+00 - 12+80 24'
 - STA. 12+80 - 38+70 22'
 - STA. 38+70 - 62+30 22'

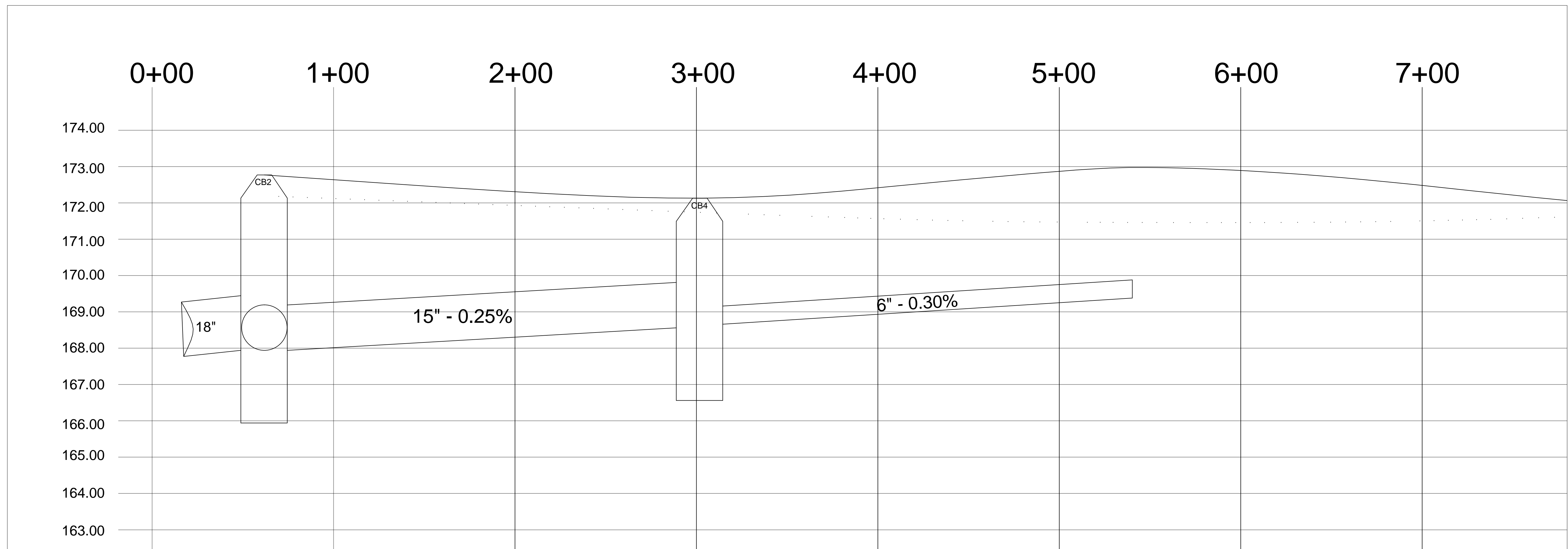

No.	Revision/Issue	Date

Firm Name and Address

Project Name and Address
 2019 NORTH RIVER ROAD
 RECONSTRUCTION PROJECT
 AUBURN, ME 04210

Project 2019 NORTH RIVER ROAD	Sheet C01
Date 10/29/2018	C01
Scale 1" = 30'	

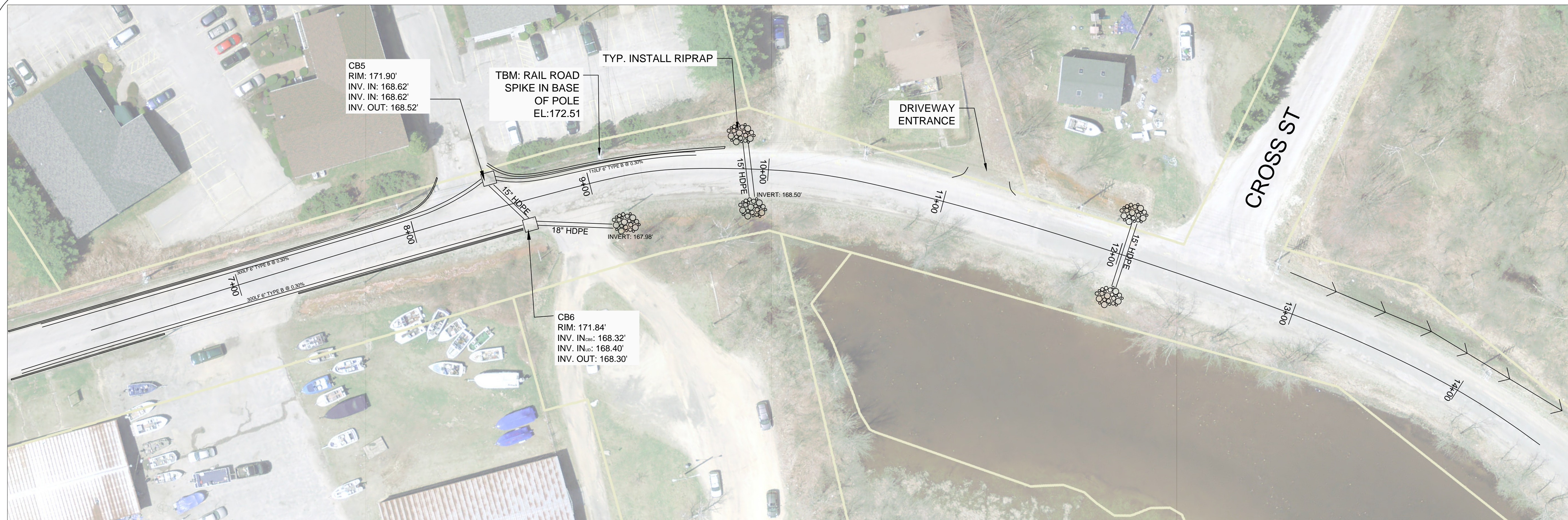

- General Notes
- DRIVEWAY BUILDUP:
 - 12" - TYPE A GRAVEL
 - 2" - 12.5mm BASE COURSE
 - 1" - 9.5mm SURFACE
 - ROADWAY BUILDUP:
 - 15" - TYPE D GRAVEL
 - 3" - TYPE A GRAVEL
 - 2" - 12.5mm HMA BASE
 - 1.5" - 12.5mm HMA SURFACE
 - ROADWAY WIDTHS:
 - STA. 1+00 - 12+80 24'
 - STA. 12+80 - 38+70 22'
 - STA. 38+70 - 62+30 22'

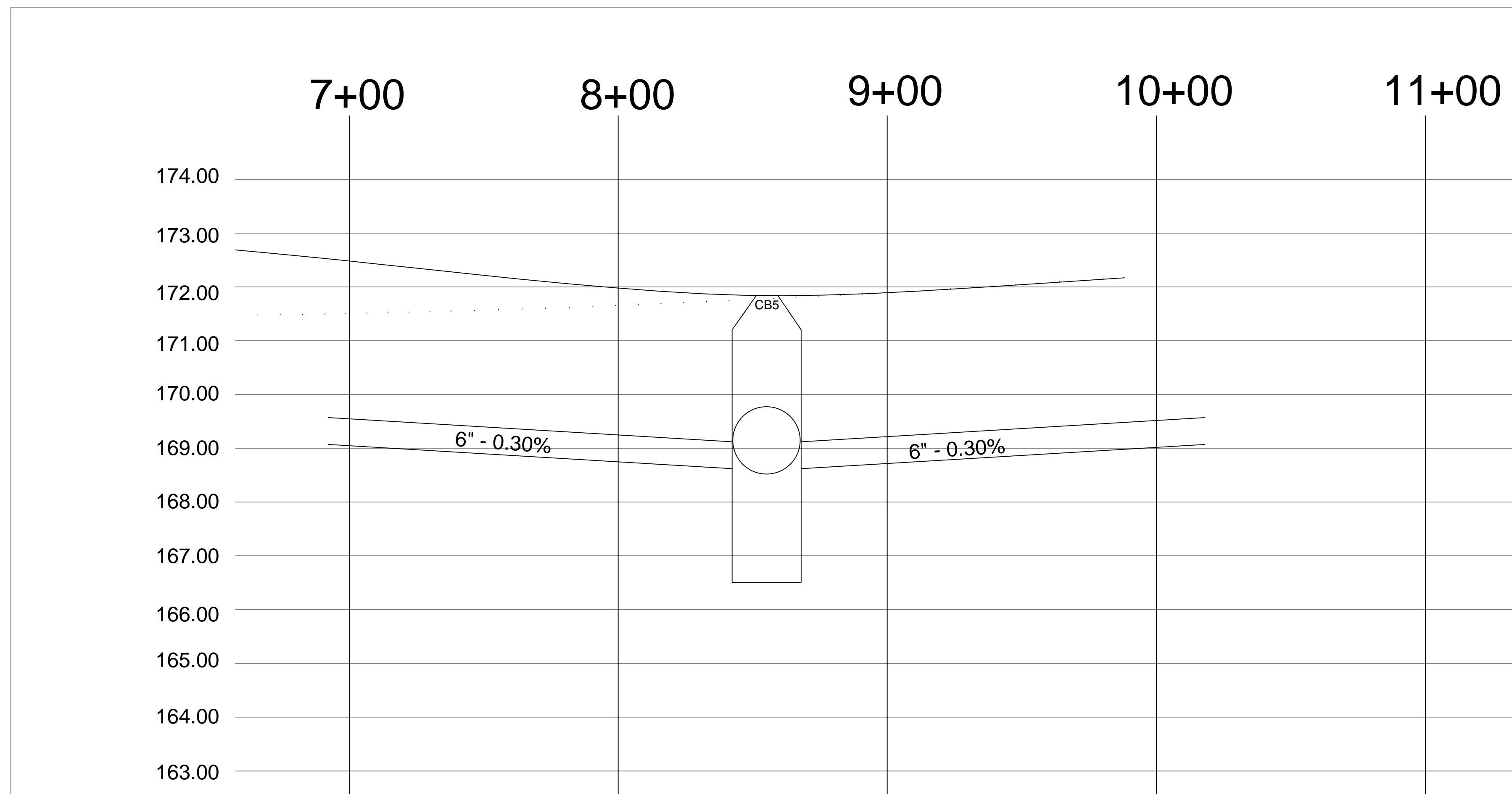

No.	Revision/Issue	Date

Firm Name and Address

Project Name and Address

2019 NORTH RIVER ROAD RECONSTRUCTION PROJECT
AUBURN, ME 04210

Project	2019 NORTH RIVER ROAD	Sheet	C02
Date	10/29/2018	Scale	
Scale	1" = 30'		

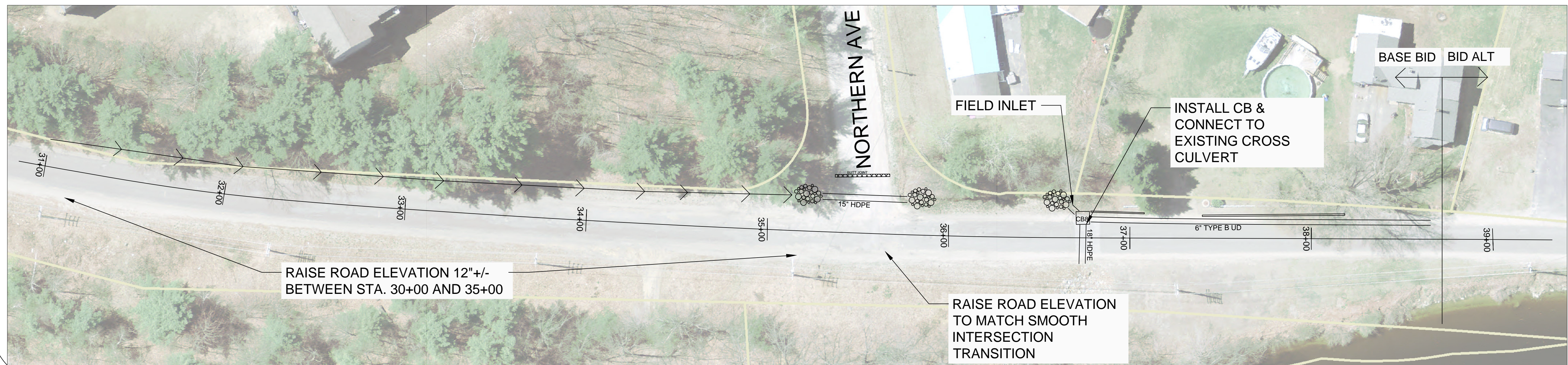
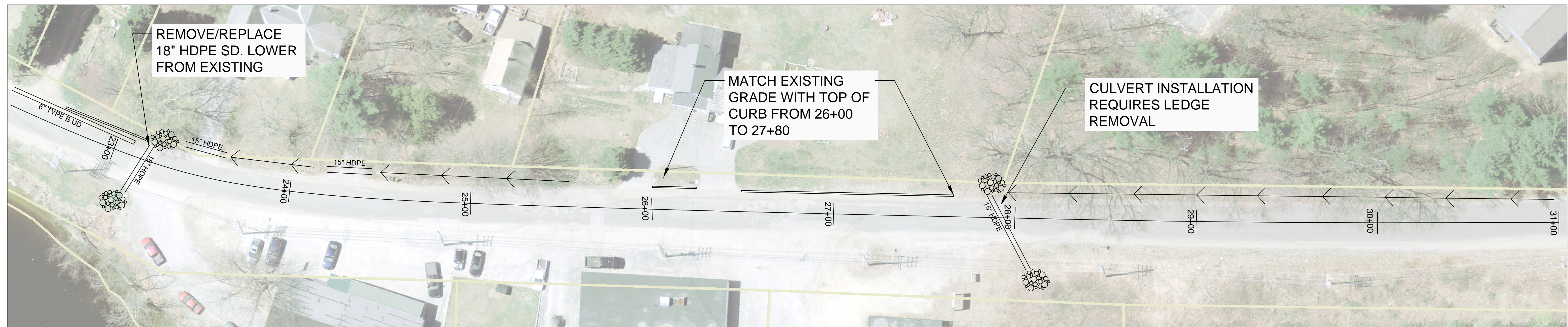
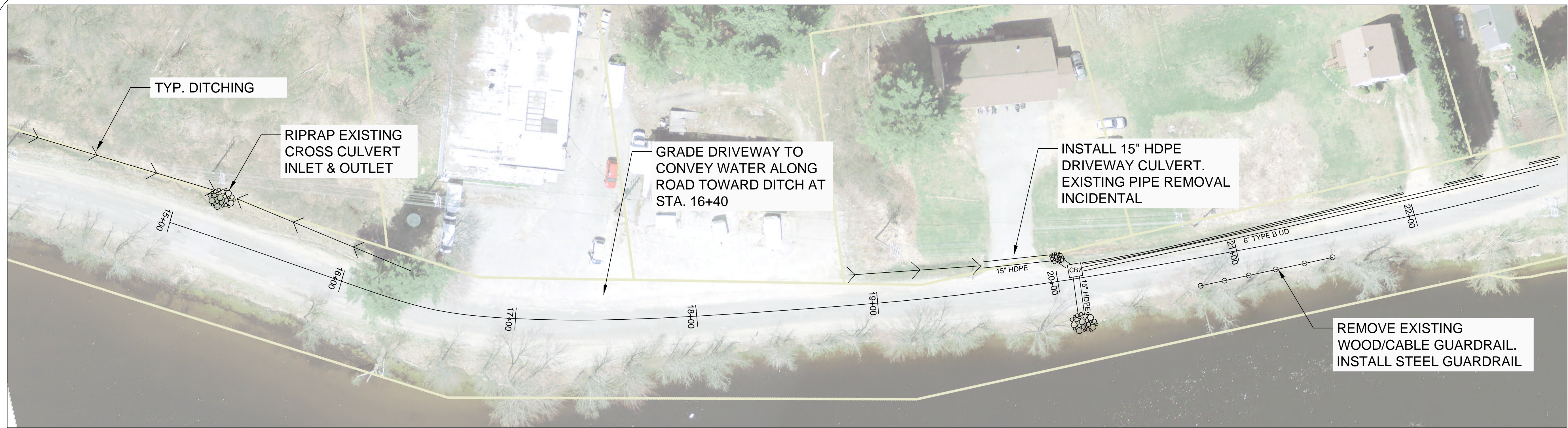

General Notes

1. DRIVEWAY BUILDUP:
 - 12" - TYPE A GRAVEL
 - 2" - 12.5mm BASE COURSE
 - 1" - 9.5mm SURFACE
2. ROADWAY BUILDUP
 - 15" - TYPE D GRAVEL
 - 3" - TYPE A GRAVEL
 - 2" - 12.5mm HMA BASE
 - 1.5" - 12.5mm HMA SURFACE
3. ROADWAY WIDTHS

STA. 1+00 - 12+80	24'
STA. 12+80 - 38+70	22'
STA. 38+70 - 62+30	22'

No.	Revision/Issue	Date

Firm Name and Address

Project Name and Address
 2019 NORTH RIVER ROAD
 RECONSTRUCTION PROJECT
 AUBURN, ME 04210

Project 2019 NORTH RIVER ROAD	Sheet C03
Date 10/29/2018	
Scale 1" = 30'	

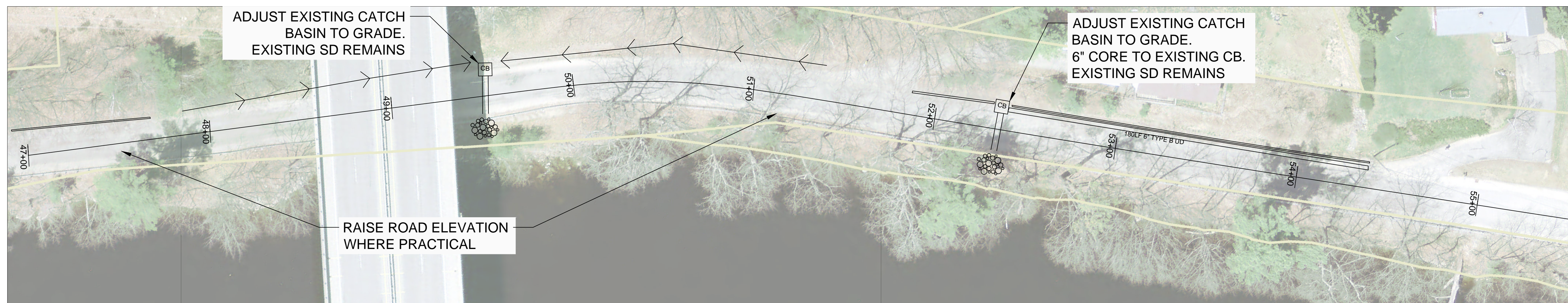
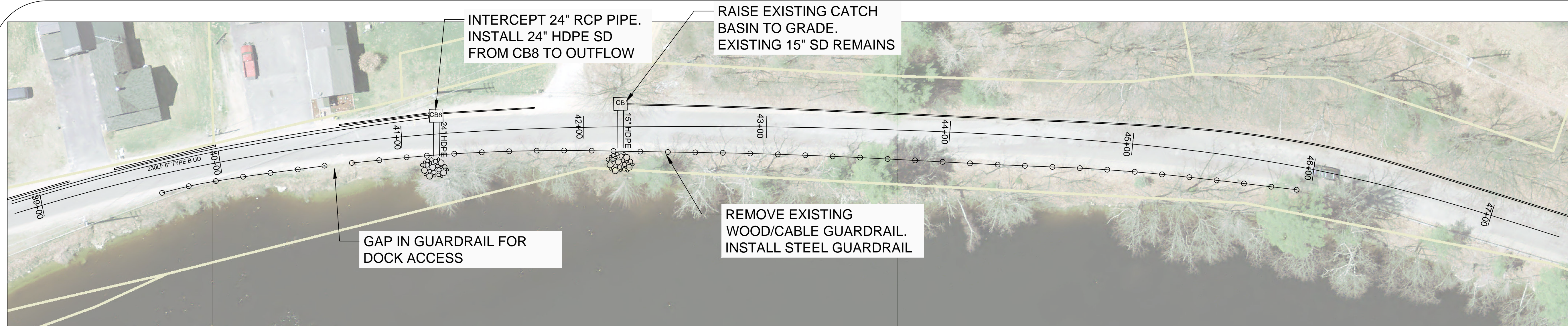

General Notes

1. DRIVEWAY BUILDUP:
 12" - TYPE A GRAVEL
 2" - 12.5mm BASE COURSE
 1" - 9.5mm SURFACE
2. ROADWAY BUILDUP
 15" - TYPE D GRAVEL
 3" - TYPE A GRAVEL
 2" - 12.5mm HMA BASE
 1.5" - 12.5mm HMA SURFACE
3. ROADWAY WIDTHS
 STA. 1+00 - 12+80 24'
 STA. 12+80 - 38+70 22'
 STA. 38+70 - 62+30 22'

No.	Revision/Issue	Date

Firm Name and Address

Project Name and Address
 2019 NORTH RIVER ROAD
 RECONSTRUCTION PROJECT
 AUBURN, ME 04210

Project 2019 NORTH RIVER ROAD	Sheet C04
Date 10/29/2018	C04
Scale 1" = 30'	